

# RACCORDS Série C

## RACCORDS RAPIDES

- Corps: Laiton OT58
- Pression maximum 261 psi, 1800 KPa ou 18 bar

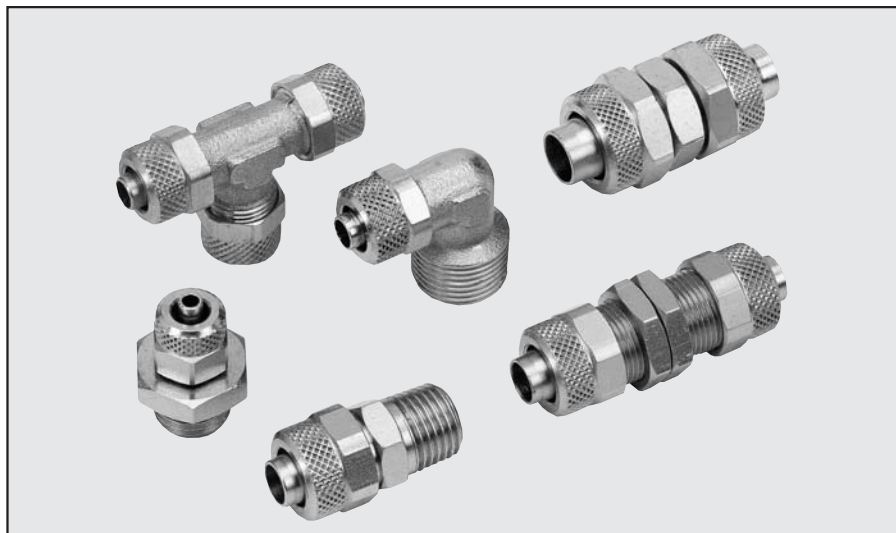

## COTES D'ENCOMBREMENT ET CODIFICATION

### C1 - PIQUAGE DROIT MALE CONIQUE

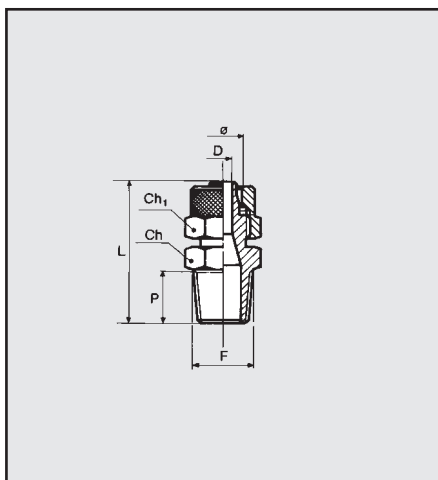

Code	Ref.	Ø	F	Ch	Ch1	P	L	D
2301017	C1	5/3	1/8	12	9	9.0	26.0	2.0
2301001	C1	6/4	1/8	12	12	8.0	26.5	3.0
2301002	C1	6/4	1/4	14	12	11.0	30.0	3.0
2301003	C1	8/6	1/8	12	14	8.0	26.5	5.0
2301004	C1	8/6	1/4	14	14	11.0	30.0	5.0
2301005	C1	8/6	3/8	17	14	11.5	31.0	5.0
2301019	C1	8/6	1/2	22	14	14.0	34.0	5.0
2301020	C1	10/8	1/8	14	16	8.0	29.0	5.0
2301006	C1	10/8	1/4	14	16	11.0	32.0	6.8
2301007	C1	10/8	3/8	17	16	11.5	33.0	6.8
2301008	C1	10/8	1/2	22	16	14.0	36.0	6.8
2301009	C1	12/10	3/8	17	19	11.5	35.0	8.5
2301010	C1	12/10	1/2	22	19	14.0	38.0	8.5
2301015	C1	15/12.5	1/2	22	22	14.0	39.5	11.0

### C1/Z - PIQUAGE DROIT MALE CYLINDRIQUE

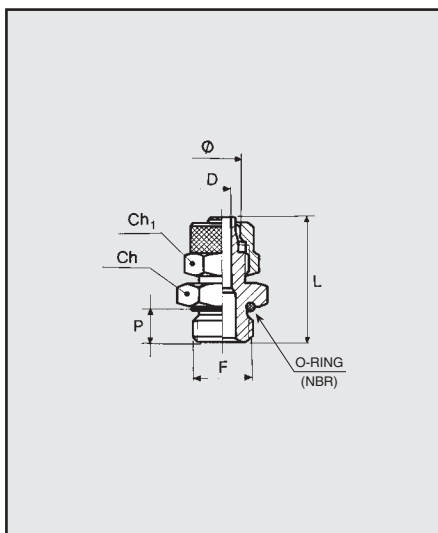

Code	Ref.	Ø	F	Ch	Ch1	P	L	D	O ring
2351001	C1/Z	4/2	M5	9	9	4.0	23.0	1.5	4x1.5
2351002	C1/Z	6/4	M5	9	9	4.0	23.0	2.7	4x1.5
2351003	C1/Z	6/4	1/8	13	12	6.0	25.0	3.0	2031
2351004	C1/Z	6/4	1/4	16	12	8.0	27.0	3.0	2043
2351005	C1/Z	8/6	1/8	14	14	6.0	25.0	5.0	2031
2351006	C1/Z	8/6	1/4	16	14	8.0	27.0	5.0	2043
2351007	C1/Z	8/6	3/8	19	14	9.0	29.0	5.0	2056
2351008	C1/Z	10/8	1/4	16	16	8.0	29.0	6.8	2043
2351009	C1/Z	10/8	3/8	19	16	9.0	31.0	6.8	2056
2351010	C1/Z	10/8	1/2	24	16	11.0	33.0	6.8	3068
2351011	C1/Z	12/10	3/8	19	19	9.0	33.0	8.5	2056
2351012	C1/Z	12/10	1/2	24	19	11.0	35.0	8.5	3068



PRODUITS PRECONISES PSA

**C1/C - PIQUAGE DROIT MALE  
CYLINDRIQUE**

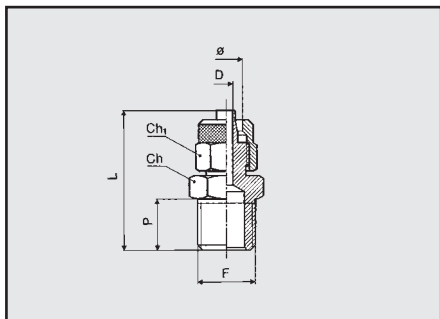

Code	Ref.	Ø	F	Ch	Ch1	P	L	D
2356001	C1/C	5/3	M5	8	9	4	20	2
2356002	C1/C	6/4	M6	9	9	5	24	3
2356003	C1/C	6/4	M12x1.5	17	12	8	28	3
2356004	C1/C	6/4	3/8	19	12	9	27	3
2356005	C1/C	8/6	M12x1.5	17	14	8	27	5

**C2 - PIQUAGE DROIT FEMELLE**

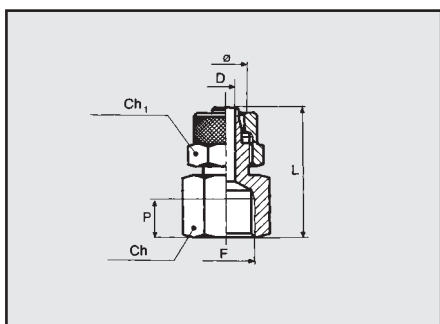

Code	Ref.	Ø	F	Ch	Ch1	P	L	D
2302001	C2	6/4	1/8	14	12	7.0	26.5	3.0
2302002	C2	6/4	1/4	17	12	8.0	29.5	3.0
2302003	C2	8/6	1/8	14	14	7.0	26.5	5.0
2302004	C2	8/6	1/4	17	14	8.0	29.0	5.0
2302005	C2	8/6	3/8	20	14	10.0	33.0	5.0
2302006	C2	10/8	1/4	17	16	8.0	31.0	6.8
2302007	C2	10/8	3/8	20	16	10.0	35.0	6.8
2302008	C2	10/8	1/2	24	16	11.0	38.0	6.8

**C3 - UNION DOUBLE**

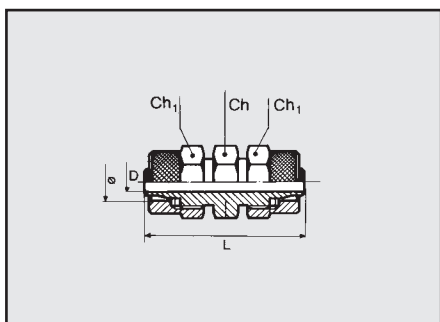

Code	Ref.	Ø	Ch	Ch1	L	D
2303001	C3	6/4	12	12	33.0	3.0
2303002	C3	8/6	12	14	33.0	5.0
2303003	C3	10/8	14	16	37.0	6.8
2303004	C3	12/10	17	19	42.0	8.5

**C4 - TRAVERSEE DE CLOISON**

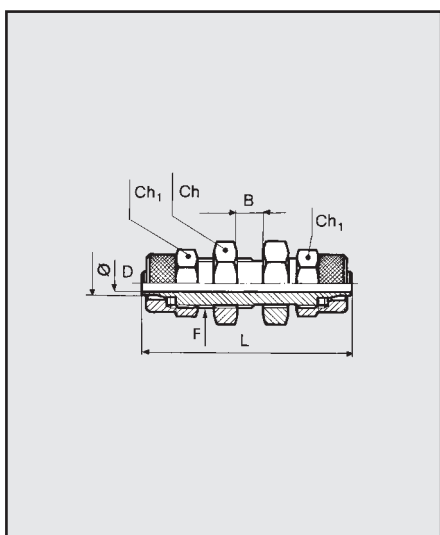

Code	Ref.	Ø	Ch	Ch1	L	D	B	F
2304001	C4	6/4	14	12	47.0	3.0	11.0	M10x1
2304002	C4	8/6	16	14	48.0	5.0	12.0	M12x1
2304003	C4	10/8	17	16	49.0	6.8	9.0	M14x1
2304004	C4	12/10	19	19	53.0	8.5	9.0	M16x1

# RACCORDS Série C

## COTES D'ENCOMBREMENT ET CODIFICATION

### C5 - EQUERRE MALE CONIQUE

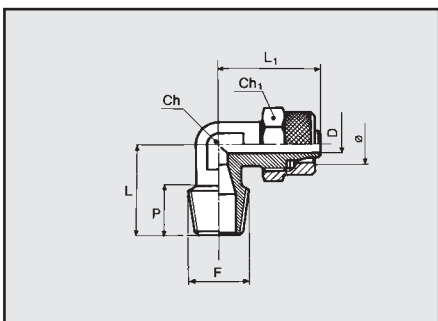

Code	Ref.	Ø	F	Ch	Ch1	P	L	L1	D
2305016	C5	5/3	1/8	8	9	8.0	17.0	22.0	2.0
2305001	C5	6/4	1/8	9	12	8.0	17.0	22.0	3.0
2305002	C5	6/4	1/4	9	12	11.0	20.0	22.0	3.0
2305003	C5	8/6	1/8	12	14	8.0	17.0	22.0	5.0
2305004	C5	8/6	1/4	12	14	11.0	20.0	22.0	5.0
2305005	C5	8/6	3/8	12	14	12.0	22.0	21.5	5.0
2305006	C5	10/8	1/4	12	16	11.0	20.5	25.0	6.8
2305007	C5	10/8	3/8	12	16	12.0	21.5	25.0	6.8
2305008	C5	10/8	1/2	17	16	14.0	26.0	28.5	6.8
2305009	C5	12/10	3/8	17	19	12.0	24.0	31.0	8.5
2305010	C5	12/10	1/2	17	19	14.0	26.0	31.0	8.5
2305017	C5	15/12.5	1/2	17	22	14.0	28.0	32.8	10.7

### C5/F - EQUERRE FEMELLE

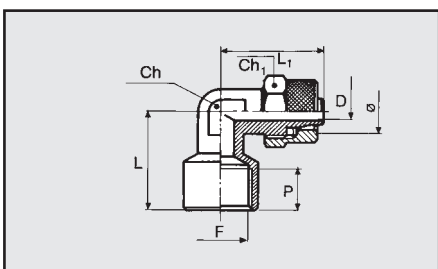

Code	Ref.	Ø	F	Ch	Ch1	L	L1	D	P
2352001	C5/F	6/4	1/8	9	12	21.0	22.0	3.0	7.0
2352002	C5/F	8/6	1/4	12	14	24.0	23.0	5.0	7.0

### C5/C - EQUERRE MALE CYLINDRIQUE

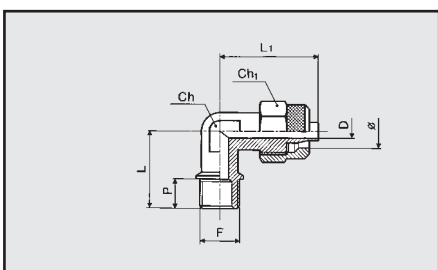

Code	Ref.	Ø	F	Ch	Ch1	P	L	L1	D
2357001	C5/C	6/4	M12x1.5	10	12	9	22	22.5	3
2357002	C5/C	8/6	M12x1.5	10	14	9	22	22.5	5

### C6 - EQUERRE EGALE

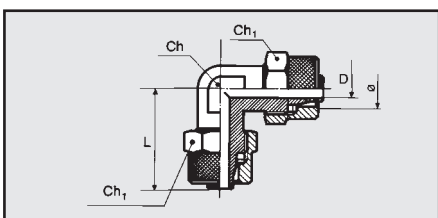

Code	Ref.	Ø	Ch	Ch1	L	D
2306001	C6	6/4	9	12	22.0	3.0
2306002	C6	8/6	12	14	22.0	5.0
2306003	C6	10/8	12	16	25.0	6.8
2306004	C6	12/10	17	19	31.0	8.5
2306006	C6	15/12.5	17	22	32.8	10.7

### C7 - TE AU CENTRE MALE CONIQUE

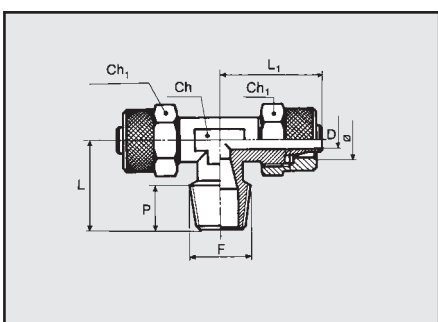

Code	Ref.	Ø	F	Ch	Ch1	P	L	L1	D
2307015	C7	5/3	1/8	8	9	8.0	17.0	22.0	2.0
2307001	C7	6/4	1/8	9	12	8.0	17.0	22.0	3.0
2307002	C7	6/4	1/4	9	12	11.0	20.0	22.0	3.0
2307003	C7	8/6	1/8	12	14	8.0	17.0	22.0	5.0
2307004	C7	8/6	1/4	12	14	11.0	20.0	22.0	5.0
2307005	C7	8/6	3/8	12	14	12.0	22.0	23.0	5.0
2307006	C7	10/8	1/4	12	16	11.0	21.0	25.0	6.8
2307007	C7	10/8	3/8	12	16	12.0	22.0	25.0	6.8
2307008	C7	10/8	1/2	17	16	14.0	26.0	28.5	6.8
2307009	C7	12/10	3/8	17	19	12.0	24.0	31.0	8.5
2307010	C7	12/10	1/2	17	19	14.0	26.0	31.0	8.5
2307016	C7	15/12.5	1/2	17	22	14.0	28.0	32.8	10.7



PRODUITS PRECONISES PSA

**C8 - TE D'EQUERRE MALE CONIQUE**

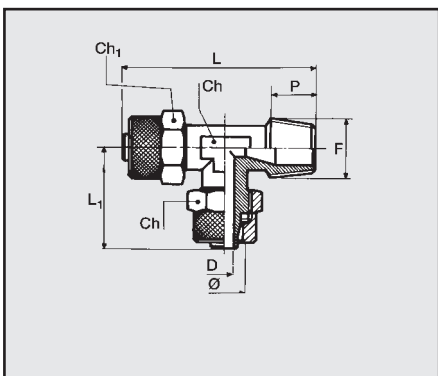

Code	Ref.	Ø	F	Ch	Ch1	P	L	L1	D
2308012	C8	5/3	1/8	8	9	8.0	39.0	22.0	2.0
2308001	C8	6/4	1/8	9	12	8.0	39.0	22.0	3.0
2308002	C8	6/4	1/4	9	12	11.0	42.0	22.0	3.0
2308003	C8	8/6	1/8	12	14	8.0	39.0	22.0	5.0
2308004	C8	8/6	1/4	12	14	11.0	42.0	22.0	5.0
2308005	C8	8/6	3/8	12	14	12.5	45.0	23.0	5.0
2308006	C8	10/8	1/4	12	16	11.5	46.0	25.0	6.8
2308007	C8	10/8	3/8	12	16	12.5	47.0	25.0	6.8
2308008	C8	10/8	1/2	17	16	13.5	54.5	28.5	6.8
2308009	C8	12/10	3/8	17	19	11.5	55.0	31.0	8.5
2308010	C8	12/10	1/2	17	19	13.5	57.0	31.0	8.5

**C9 - TE EGAL**

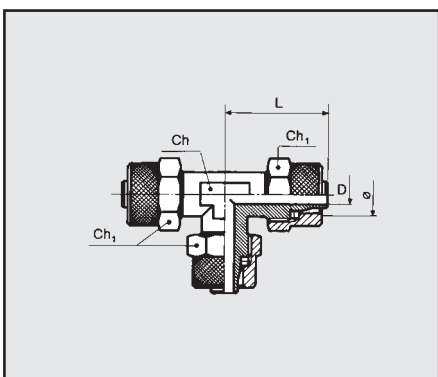

Code	Ref.	Ø	Ch	Ch1	L	D
2309001	C9	6/4	9	12	22.0	3.0
2309002	C9	8/6	12	14	22.0	5.0
2309003	C9	10/8	12	16	25.0	6.8
2309004	C9	12/10	17	19	31.0	8.5
2309007	C9	15/12.5	17	22	32.8	10.7

**C10 - ECROU DE BLOCAGE**

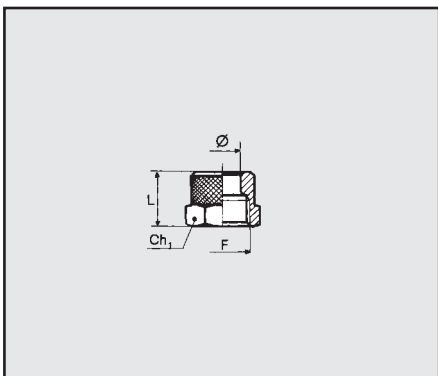

Code	Ref.	Ø	F	Ch1	L
2310001	C10	4/2	M7x0.5	9	9.0
2310009	C10	5/3	M7x0.5	9	9.0
2310002	C10	6/4- M5	M8x0.5	9	9.0
2310003	C10	6/4	M10x1	12	11.0
2310004	C10	8/6	M12x1	14	11.0
2310005	C10	10/8	M14x1	16	12.0
2310006	C10	12/10	M16x1	19	12.0
2310011	C10	15/12.5	M20x1	22	16.0

**C11 - CROIX EGALE**

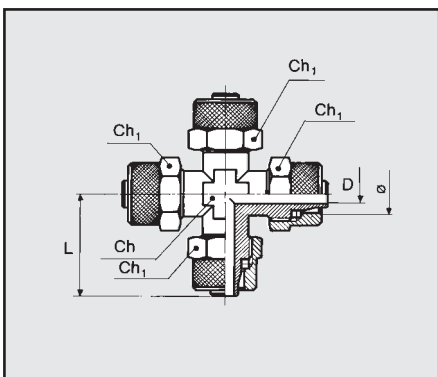

Code	Ref.	Ø	Ch	Ch1	L	D
2311001	C11	6/4	10	12	21.5	3.0
2311002	C11	8/6	10	14	22.0	5.0
2311003	C11	10/8	12	16	24.5	6.8